The logo for TECHNE, consisting of the word "TECHNE" in a bold, blue, sans-serif font, enclosed within a blue oval border. A horizontal blue line passes through the center of the oval.

TECHNE

HB-1D

Hybridisation oven

OPERATOR'S MANUAL

Issue 27
11/2014

The logo for Bibby Scientific, featuring the word "Bibby" in a black serif font, followed by "Scientific" in a black sans-serif font. A blue oval graphic is positioned behind the letter "i" in "Scientific".

Bibby Scientific

CONTENTS

INTRODUCTION	5
BEFORE USE.....	6
Unpacking.....	6
SAFETY AND INSTALLATION.....	7
Warning	7
Operator Safety	7
Installation	7
Environmental Conditions	8
Guarantee.....	8
SÉCURITÉ ET CONSIGNES D'INSTALLATION.....	9
Avertissement.....	9
Sécurité de l'opérateur	9
Installation	9
Conditions environnementales.....	10
Garantie.....	10
SICHERHEITS- UND INSTALLATIONSINFORMATIONEN.....	11
Achtung	11
Sicherheit des Bedienpersonals.....	11
Inbetriebnahme.....	11
Umweltbedingungen.....	12
Garantie.....	12
INFORMAZIONI SULLA SICUREZZA E L'INSTALLAZIONE	13
Avvertenza.....	13
Sicurezza dell'operatore	13
Installazione.....	13
Condizioni ambientali	14
Garanzia	14
INFORMACIÓN DE SEGURIDAD E INSTALACIÓN.....	15
Advertencia.....	15
Seguridad del operario	15
Instalación	15
Condiciones ambientales	16
Garantía.....	16
CONTACT INFORMATION	17
SPECIFICATIONS.....	18
INSTALLATION.....	19
OPERATION	21
Switching On	21
The front panel controls.....	21
Setting the speed	21
Setting the temperature.....	22
Indicators	23
Hybridisation tubes.....	24
Installing the hybridisation tubes.....	26
Basic protocol for Southern Hybridisations	26
Warning	26
User maintenance	27
ADDITIONAL INFORMATION.....	28
Fault Finding.....	28
Fuses.....	28
Safety over-temperature cut-out.....	28
If an incorrect message is displayed	28
Insulation testing.....	28

Support contacts..... 29
SPARES AND ACCESSORIES.....30
DECLARATION OF CONFORMITY31

INTRODUCTION

Please read all the information in this manual before using the unit.

The Techne HB-1D hybridisation oven is ideal for blotting techniques in which RNA, DNA or protein are immobilised onto nylon or nitrocellulose filters. Several filters can be hybridised simultaneously in a single tube while the rotating design ensures volumes as low as 5ml can be used and recovered.

The HB-1D has unique “slot-in” tubes with adjustable tube rotation speeds of 0 to 20 rpm; controllable to suit your application. The tubes and other accessories can be accommodated together for multiple applications and the unit can hold up to 24 mini or 6 large glass tubes. The temperature can be set from 10°C above ambient to 100°C and offers excellent temperature accuracy and uniformity.

For safety, the unit has a double glazed door to shield the immediate environment from radiation. In addition, protective casing and non-drip tube design minimises risk to the user. Included is a removable drip tray for easy cleaning should spillages occur.

The HB-1D has adjustable feet for levelling on uneven surfaces and it's compact design saves on valuable laboratory space.

The operating instructions in this Operator's Manual cover the following models of the Techne HB-1D:

Model number	Description	Voltage
FHB1DE	HB-1D hybridisation incubator	230V, 50/60Hz
FHB1DG	HB-1D hybridisation incubator, (including 3 large tubes FHB12)	230V, 50/60Hz
FHB1DP	HB-1D hybridisation incubator	120V, 50/60Hz
FHB1DB	HB-1D hybridisation incubator, (including 3 large tubes FHB12)	120V, 50/60Hz

BEFORE USE

Before using the HB-1D please make sure you have read this manual carefully. If there is any doubt relating to the proper use of this equipment, the staff at Bibby Scientific Ltd. or your supplier will be happy to assist you.

UNPACKING

When unpacking the unit please ensure that the following have been removed from the packaging:

- HB-1D oven including drip tray
- Mains cables (UK and EU or US)
- Tube of silicon grease
- Hybridisation tubes x 3 (if included)
- Operator's manual
- Guarantee card
- Decontamination certificate

The user is advised to keep the original packaging in case the instrument ever needs to be returned for service or repair. Bibby Scientific Ltd. accepts no responsibility for damage incurred unless the unit is correctly packed and transported in its original packaging.



SAFETY AND INSTALLATION

Please read all the information in this manual before using the HB-1D.

WARNING

HIGH TEMPERATURES ARE DANGEROUS: they can cause serious burns to operators and ignite combustible material.

Techne have taken great care in the design of these units to protect operators from hazards, but operators should pay attention to the following points:



- USE CARE AND WEAR PROTECTIVE GLOVES TO PROTECT HANDS
- DO NOT use combustible substances near hot objects
- DO NOT operate the instrument in the vicinity of inflammable liquids or gases.
- DO NOT place any liquid directly into the instrument.

OPERATOR SAFETY

All operators of Techne equipment must have available the relevant literature needed to ensure their safety. It is important that only suitably trained personnel operate this equipment, in accordance with the instructions contained in this manual and with general safety standards and procedures. If the equipment is used in a manner not specified by Bibby Scientific Ltd. the protection provided by the equipment to the operator may be impaired.

All Techne instruments are designed to conform to international safety requirements and are fitted with an over-temperature cut-out.

If a safety problem should be encountered, switch off the unit at the mains socket and remove the plug from the electricity supply.

INSTALLATION

The instrument should be carried using both hands. Never move or carry the instrument when in use or connected to the mains electricity supply.

1. All Techne instruments are supplied with a power cable; this may be integral or plug-in.

2.  Before connecting the instrument to the mains electricity supply, check the voltage against the rating plate (located on the back of the unit). **Please note that the unit must be earthed to ensure proper electrical safety.** Connect the mains cable to a suitable plug according to the table below.

Connections	230V	120V
Live	Brown	Black
Neutral	Blue	White
Earth	Green/yellow	Green

UK ONLY: The fused plug supplied with the mains cable is fitted with a 5 amp fuse to protect the instrument and the operator.

Note that units marked 230V on the rating plate work at 220V; units marked 120V work at 110V. In both cases, however, the heating rate will degrade by approximately 8%.

3. Place the unit on a suitable flat bench or in a fume cupboard if required, ensuring that the air inlet vents on the underside are free from obstruction.

4. Plug the mains cable into the socket on the back of the instrument.

5. Switch on the instrument. Symbols on or near the power switch of the unit have the following meanings:

- I Mains Switch On
- O Mains Switch Off

Replacement cable

Should the mains lead need replacement, a cable of 1mm² of harmonized code H05VV-F connected to an IEC320 plug should be used. **IF IN DOUBT CONSULT A QUALIFIED ELECTRICIAN.**

ENVIRONMENTAL CONDITIONS

The HB-1D is designed operate under the following conditions:

- Indoor use
- Ambient temperature range +5°C to +40°C
- Altitude to 2000m
- Relative humidity up to 80%
- Mains supply fluctuations not exceeding 10%
- Over voltage category II IEC 60364-4-443
- Pollution degree 2
- Use with a minimum distance all-around of 200mm from walls or other items

Note: The control specifications are quoted at an ambient temperature of 20°C. The specification may deteriorate outside an ambient temperature of between 18°C and 30°C.

The instrument has been tested for radio frequency interference and is certified under EN61326.

GUARANTEE

The instrument is guaranteed against any defect in material or workmanship for the period specified on the enclosed guarantee card. This period is effective from the date of purchase; within this period all defective parts will be replaced free of charge provided that the defect is not the result of an accident, misuse or negligence. Servicing under this guarantee should be obtained from the supplier of the instrument.

This manual has been prepared for the convenience of Techne's customers and nothing in this manual shall be taken as a warranty, condition or representation concerning the description, merchantability, fitness for purpose or otherwise of the unit or components.

Notwithstanding the description and specification(s) of the instruments contained in the operator's manual, Techne reserves the right to make such changes as it sees fit to the instruments or to any of the components.

SÉCURITÉ ET CONSIGNES D'INSTALLATION

Veuillez lire attentivement toutes les instructions de ce document avant d'utiliser le HB-1D.

AVERTISSEMENT

Les TEMPÉRATURES ÉLEVÉES SONT DANGEREUSES car elles peuvent provoquer de graves brûlures chez l'opérateur et enflammer les matériaux combustibles.

Techne a apporté un soin tout particulier à la conception de ces appareils de façon à assurer une protection maximale des opérateurs, mais il est recommandé aux utilisateurs de porter une attention spéciale aux points suivants :



- PROCÉDER AVEC PRUDENCE ET PORTER DES GANTS POUR SE PROTÉGER LES MAINS
- NE PAS utiliser de matériaux combustibles auprès d'objets chauds.
- NE PAS utiliser l'appareil à proximité de liquides ou de gaz inflammables
- NE PAS verser de liquides directement dans l'appareil.

SECURITE DE L'OPÉRATEUR

Tous les utilisateurs de produits Techne doivent avoir pris connaissance des consignes et instructions nécessaires à la garantie de leur sécurité. Important: cet appareil doit impérativement être manipulé par un personnel qualifié et être utilisé selon les instructions données dans ce document, en accord avec les normes et procédures de sécurité générales. Dans le cas où cet appareil ne serait pas utilisé selon les consignes précisées par Bibby Scientific Ltd., la protection pour l'utilisateur ne serait alors plus garantie.

Tous les appareils Techne sont conçus pour répondre aux normes de sécurité internationales et sont dotés d'un coupe-circuit en cas de surchauffe.

En cas de problème de sécurité, couper l'alimentation électrique au niveau de la prise murale et enlevez la prise connectée à l'appareil.

INSTALLATION

Porter l'appareil à deux mains. Ne jamais déplacer ou transporter l'appareil lorsqu'il est en fonctionnement ou branché à l'alimentation électrique.

1. Tous les appareils Techne sont livrés avec un câble d'alimentation, qui peut être intégré à l'appareil ou à raccorder.

2.  Avant de raccorder l'appareil à l'alimentation électrique sur secteur, vérifier la tension requise indiquée sur la plaque d'identification (située au dos de l'appareil). **Il est important que l'appareil soit relié à la terre pour assurer la protection électrique requise.** Brancher le câble secteur sur une prise appropriée, voir tableau ci-après.

Connexions	230 V	120 V
Phase	Marron	Noir
Neutre	Bleu	Blanc
Terre	Vert/jaune	Vert

ROYAUME-UNI SEULEMENT: La prise avec fusible intégré fournie avec le câble secteur est munie d'un fusible 5 A destiné à protéger l'appareil et l'utilisateur.

Remarque : les appareils dont la plaque indique 230 V peuvent fonctionner sur 220 V, et ceux dont la plaque indique 120 V peuvent fonctionner sur 110 V. Dans les deux cas cependant, la capacité de chauffage diminuera d'environ 8 %.

3. Placer l'appareil sur une surface plane ou si nécessaire sous une hotte d'aspiration, veiller à ce que les trous d'aération situés sous l'appareil ne soient pas obstrués.
4. Raccorder le câble d'alimentation à la prise située à l'arrière de l'appareil.
5. Allumer l'appareil. Les symboles situés sur ou à côté de l'interrupteur de l'appareil ont la signification suivante :

- I Interrupteur secteur en position Marche
- O Interrupteur secteur en position Arrêt

Câble de rechange

S'il s'avère nécessaire de remplacer le cordon d'alimentation, utiliser un câble de 1 mm² conforme à la norme H05VV-F relié à une prise IEC320. **EN CAS DE DOUTE, CONSULTER UN ELECTRICIEN QUALIFIE.**

CONDITIONS ENVIRONNEMENTALES

Le HB-1D est conçu pour fonctionner dans les conditions suivantes:

- Pour un usage intérieur seulement
- Température ambiante +5 °C à +40 °C
- Altitude inférieure à 2000m
- Humidité relative ne dépassant pas 80%
- Fluctuations de l'alimentation n'excédant pas 10% de la valeur nominale
- Catégorie II IEC 60364-4-443 de surtension
- Degré de pollution 2
- Utiliser à une distance minimale sur le pourtour de 200mm par rapport aux murs et autres équipements

Remarque: Les paramètres sont indiqués pour une température ambiante de 20°C. Ces caractéristiques peuvent se détériorer en dehors d'une température ambiante de 18 à 30°C.

L'appareil a été testé en matière de radiofréquences et est certifié selon la norme EN61326.

GARANTIE

L'appareil est garanti contre tout défaut de matériaux ou vice de fabrication pendant la période précisée sur la carte de garantie jointe. Cette période s'applique à compter de la date d'achat. Au cours de cette période, toutes les pièces défectueuses seront remplacées gratuitement dans la mesure où la défaillance n'est pas due à un accident, une mauvaise utilisation ou une négligence. Toute réparation sous garantie sera effectuée par le fournisseur.

Le présent manuel a été exclusivement rédigé à l'attention des clients de la marque Techne et rien dans son contenu ne doit être pris comme une garantie, une condition ou une affirmation concernant la description, la commercialisation, l'adéquation à un usage particulier de l'appareil ou de ses composants.

Malgré la description et les caractéristiques techniques des appareils données dans le manuel de l'utilisateur, la société Techne se réserve le droit d'apporter les changements nécessaires à l'appareil ou à tout élément qui entre dans sa composition.

SICHERHEITS- UND INSTALLATIONSINFORMATIONEN

Lesen Sie diese Anleitung vor Verwendung des HB-1D bitte sorgfältig durch.

ACHTUNG

HOHE TEMPERATUREN STELLEN EINE GEFAHRENQUELLE DAR. Sie können schwere Brandverletzung verursachen und brennbare Stoffe entzünden.

Techne hat bei der Konstruktion dieses Gerätes sehr darauf geachtet, daß der Bediener vor Gefahren geschützt ist. Dennoch sollten Sie auf die folgenden Punkte achten:



- UMSICHTIG VORGEHEN UND SCHUTZHANDSCHUHE TRAGEN
- KEINE brennbaren Stoffe in der Nähe heißer Gegenstände verwenden
- Das Gerät NICHT in der Nähe entzündlicher Flüssigkeiten oder Gase betreiben
- Flüssigkeiten NICHT direkt auf das Gerät auftragen.

SICHERHEIT DES BEDIENPERSONALS

Alle Benutzer von Techne Geräten müssen Zugang zu der entsprechenden Literatur haben, um ihre Sicherheit zu gewähren. Es ist wichtig, daß diese Geräte nur von entsprechend geschultem Personal betrieben werden, das die in dieser Gebrauchsanweisung enthaltenen Maßnahmen und allgemeine Sicherheitsbestimmungen und -vorkehrungen beachtet. Wenn das Gerät anders eingesetzt wird als vom Hersteller empfohlen, kann dies die persönliche Sicherheit des Anwenders beeinträchtigen.

Die Geräte von Techne entsprechen den internationalen Sicherheitsbestimmungen und sind mit einem automatischen Übertemperaturabschalter ausgestattet.

Wenn ein Sicherheitsproblem auftreten sollte, muß das Gerät ausgeschaltet und vom Stromnetz getrennt werden.

INBETRIEBNAHME

Das Gerät mit beiden Händen tragen. Das Gerät unter keinen Umständen transportieren, wenn es in Betrieb ist, oder während das Gerät noch am Netz angeschlossen ist.

1. Alle Geräte von Techne werden mit einem Netzkabel geliefert, das entweder eingesteckt wird oder fest mit dem Gerät verbunden ist.

2.  Vor dem Anschluss bitte kontrollieren, ob die Stromversorgung den Angaben auf dem Typenschild (auf der Geräterückseite) entspricht. **Um die elektrische Sicherheit zu gewährleisten, muss dieses Gerät geerdet werden.** Schließen Sie das Netzkabel entsprechend der folgenden Tabelle an einen geeigneten Stecker an.

Anschluss	230V	120V
Phase	Braun	Schwarz
Neutral	Blau	Weiß
Erde	Grün/Gelb	Grün

NUR FÜR GROSSBRITANNIEN: der mit dem Netzkabel gelieferte Sicherungsstecker enthält eine 5 Amp. Sicherung zum Schutz des Geräts und des Anwenders.

Geräte, die für 230 Volt ausgelegt sind, können auch bei 220 Volt arbeiten, Geräte für 120 Volt auch bei 100 Volt. In beiden Fällen verringert sich die Aufheizrate um ca. 8%.

3. Stellen Sie das Gerät auf einen geeigneten ebenen Tisch oder in einem Abzugsschrank auf und sorgen Sie dafür, dass die Lufteinlassschlitze auf der Geräteunterseite nicht blockiert sind.
4. Stecken Sie das Netzkabel in die Buchse auf der Geräterückseite ein.
5. Schalten Sie das Gerät ein:

- I Netzschalter Ein
- O Netzschalter Aus

Ersatzkabel

Bei einem eventuellen Austausch des Netzkabels wird ein Kabel vom Typ H05VV-F mit 1 mm² Aderquerschnitt und Europastecker (IEC 320) benötigt. **IM ZWEIFELSFALL EINEN ELEKTROFACHMANN HINZUZIEHEN.**

UMWELTBEDINGUNGEN

Der HB-1D ist für den Einsatz unter folgenden Bedingungen ausgelegt:

- Gebrauch in Innenräumen
- Umgebungstemperatur zwischen +5°C to +40°C
- Höhe: bis zu 2000 m
- Relative Feuchte nicht über 80%
- Netzspannungsschwankungen nicht über 10%
- Überspannungsklasse 2 IEC 60364-4-443
- Verschmutzungsgrad 2
- Der Mindestabstand zwischen dem Gerät und umgebenden Wänden oder Gegenständen muss 200mm betragen

Hinweis: Die Gerätespezifikationen beziehen sich auf eine Umgebungstemperatur von 20°C und können sich außerhalb des Bereichs 18°C bis 30°C verschlechtern.

Das Gerät wurde auf HF-Störeinflüsse geprüft und entspricht den EMV-Bedingungen nach EN61326.

GARANTIE

Techne gewährleistet, dass dieses Gerät für den auf der Garantiekarte angegebenen Zeitraum keine Herstellungs- und Materialmängel aufweist. Dieser Zeitraum tritt ab dem Verkaufsdatum in Kraft. Innerhalb dieses Zeitraums werden alle defekten Teile kostenlos ausgetauscht, soweit der Defekt nicht auf einen Unfall, Missbrauch oder Nachlässigkeit zurückzuführen ist. Wartungsarbeiten, die unter diese Garantie fallen, müssen von der Verkaufsstelle für dieses Gerät gehandhabt werden.

Diese Anleitung wurde zur Information der Kunden von Techne erstellt und stellt in keinster Weise eine Gewährleistung, Bedingung oder Darstellung bezüglich der Beschreibung, Marktgängigkeit oder Zweckdienlichkeit dieser Geräte oder Bauteile dar.

Unabhängig von Beschreibung und Spezifikation(en) des hier beschriebenen Geräts behält sich Techne das Recht vor, Änderungen an diesem Gerät oder dessen Bauteilen vorzunehmen.

INFORMAZIONI SULLA SICUREZZA E L'INSTALLAZIONE

Leggere attentamente il presente manuale prima di usare il HB-1D.

AVVERTENZA

Le ALTE TEMPERATURE SONO PERICOLOSE in quanto possono provocare serie ustioni agli operatori e dare fuoco al materiale combustibile.

La Techne ha posto particolare cura nel progettare questo strumento, al fine di proteggere gli operatori da eventuali pericoli, ma gli utilizzatori devono prestare attenzione ai seguenti punti:



- PRESTARE ATTENZIONE ED INDOSSARE GUANTI PROTETTIVI PER LE MANI
- NON usare sostanze combustibili vicino ad oggetti caldi
- NON mettere in funzione lo strumento nei pressi di liquidi o gas infiammabili
- NON collocare alcun tipo di liquido direttamente nello strumento.

SICUREZZA DELL'OPERATORE

Il personale che utilizza l'apparecchiatura Techne deve avere a disposizione la documentazione necessaria al fine di assicurare la loro incolumità. È importante che solo personale adeguatamente addestrato utilizzi questo apparecchio, in conformità alle istruzioni contenute in questo manuale e nel rispetto delle normative e procedure generali di sicurezza. Se l'apparecchio è utilizzato in modo non specificato da Bibby Scientific Ltd., la protezione fornita dall'apparecchiatura all'utilizzatore potrebbe essere a rischio.

Tutte le unità Techne sono state progettate in conformità ai requisiti internazionali di sicurezza e sono equipaggiate con un interruttore anti surriscaldamento.

Se si dovesse verificare qualche problema di sicurezza, disconnettere l'apparecchio dalla rete.

INSTALLAZIONE

Occorre trasportare lo strumento usando entrambe le mani. Non spostare né trasportare lo strumento quando è in funzione o collegato all'alimentazione elettrica di rete.

1. Tutti gli strumenti Techne sono forniti con un cavo di alimentazione; può essere integrale o plugin.

2.  Prima di collegare lo strumento all'alimentazione elettrica di rete, controllare la tensione confrontandola con la targhetta riportante i valori nominali (si trova sul retro dell'unità). **Notare che al fine di garantire la corretta sicurezza elettrica, occorre che l'unità sia messa a terra.** Collegare il cavo di rete ad una presa idonea secondo la tabella riportata alla pagina successiva.

Connessione	230V	120V
Sotto tensione	Marrone	Nero
Neutro	Blu	Bianco
Terra	Verde/giallo	Verde

SOLO REGNO UNITO: la spina con fusibile fornita con il cavo di rete è dotata di un fusibile da 5 Amp per proteggere lo strumento e l'utente.

Tenere presente che gli apparecchi riportanti sulla targhetta 230 V funzionano a 220V. Gli apparecchi riportanti 120V funzionano a 110V. Comunque, in entrambi i casi la velocità di riscaldamento diminuirà approssimativamente dell'8%.

3. Collocare l'unità su un banco piano idoneo o in una cappa aspirante se necessario, assicurandosi che gli sfiiati delle prese d'aria nella parte inferiore non siano ostruiti.
4. Inserire il cavo di rete nella presa che si trova sul retro dello strumento.
5. Accendere lo strumento:
 - I Interruttore di rete Acceso
 - O Interruttore di rete Spento

Cavo di ricambio

Qualora occorra sostituire il cavo di rete, si dovrà utilizzare un cavo di 1mm² codice armonizzato H05VV-F collegato ad una spina IEC 320. **IN CASO DI DUBBIO, RIVOLGERSI A UN ELETTRICISTA QUALIFICATO.**

CONDIZIONI AMBIENTALI

Il HB-1D è stato progettato per funzionare nelle seguenti condizioni:

- uso interno
- range di temperatura ambiente da +5°C a +40°C
- altitudine massima 2000 m.
- umidità relativa non superiore all'80%
- oscillazione dell'alimentazione di rete non superiore al 10%
- categoria di sovratensione II IEC 60364-4-443
- grado di inquinamento 2
- Con distanza minima tra i lati dell'apparecchio e il muro o altri oggetti di almeno 200mm

Nota: le specifiche di controllo sono indicate ad una temperatura ambiente di 20°C. Le specifiche potrebbero peggiorare fuori da una temperatura ambiente compresa tra 18°C e 30°C.

Lo strumento è stato collaudato per interferenze da radiofrequenze ed è certificato secondo la norma EN61326.

GARANZIA

Lo strumento è garantito da qualsiasi difetto nei materiali o nella lavorazione per il periodo specificato nella scheda di garanzia allegata. Questo periodo è valido dalla data di acquisto; entro tale periodo, tutte le parti difettose saranno sostituite gratuitamente, a condizione che il difetto non sia la conseguenza di un incidente, un uso improprio o negligenza. L'assistenza secondo quanto stabilito dalla presente garanzia deve essere ottenuta dal fornitore dello strumento.

Il presente manuale è stato preparato ad uso dei clienti di Techne e niente di quanto in esso contenuto costituisce garanzia, condizione o rappresentanza riguardo la descrizione, la commerciabilità, l'idoneità allo scopo o altrimenti dell'unità o dei componenti.

Nonostante la descrizione e le specifiche dello strumento contenuti nel manuale dell'operatore, Techne si riserva il diritto di apportare le modifiche ritenute opportune agli strumenti o a qualsiasi loro componente.

INFORMACIÓN DE SEGURIDAD E INSTALACIÓN

Lea atentamente este manual antes de utilizar el HB-1D.

ADVERTENCIA

LAS ALTAS TEMPERATURAS SON PELIGROSAS, ya que pueden ocasionar quemaduras graves a los operarios y prender el material combustible. Techne ha puesto gran cuidado en el diseño de estos aparatos para proteger al usuario de cualquier peligro; aún así se deberá prestar atención a los siguientes puntos:



- TENGA CUIDADO Y LLEVE GUANTES DE PROTECCIÓN PARA PROTEGERSE LAS MANOS
- NO utilice sustancias combustibles cerca de objetos calientes
- NO utilice el instrumento cerca de líquidos o gases inflamables
- NO coloque un líquido directamente en el instrumento.

SEGURIDAD DEL OPERARIO

Todos los usuarios de equipos Techne deben disponer de la información necesaria para asegurar su seguridad. De acuerdo con las instrucciones contenidas en este manual y con las normas y procedimientos generales de seguridad, es muy importante que sólo personal debidamente capacitado opere estos aparatos. De no ser así, la protección que el equipo le proporciona al usuario puede verse reducida.

Todos los equipos Techne han sido diseñados para cumplir con los requisitos internacionales de seguridad y traen incorporados un sistema de desconexión en caso de sobre temperatura.

En caso de que surgiera un problema de seguridad, desconecte el equipo de la red.

INSTALACIÓN

El instrumento se debe transportar con las dos manos. No mueva ni lleve el instrumento cuando se utilice o esté conectado al suministro eléctrico principal.

1. Todos los instrumentos Techne se suministran con un cable de alimentación, que puede ser integrado o 'enchufable'.

2.  Antes de conectar el instrumento al suministro eléctrico, compruebe que el voltaje coincida con el indicado en la placa de régimen (situada en la parte trasera de la unidad). **El instrumento debe disponer de una toma de tierra para garantizar la seguridad eléctrica adecuada.** Conecte el cable de alimentación a un enchufe adecuado según la siguiente tabla.

Conexión	230V	120V
Con corriente	Marrón	Negro
Neutro	Azul	Blanco
Toma de tierra	Verde/amarillo	Verde

SÓLO PARA EL REINO UNIDO: El enchufe suministrado con el cable de alimentación incluye un fusible de 5 amperios para ofrecer protección al instrumento y al usuario.

Asegúrese de que los equipos marcados 230V en la placa indicadora funcionan a 220V y de que los equipos marcados 120V funcionan a 110V. No obstante, en ambos casos la velocidad de calentamiento se verá reducida en un 8% aproximadamente.

3. Sitúe la unidad sobre una mesa plana o en una campana de laboratorio si es necesario, y asegúrese de que los orificios de ventilación situados en la parte inferior no tienen ninguna obstrucción.
4. Conecte el cable de alimentación en el enchufe situado en la parte trasera del instrumento.
5. Encienda el instrumento:
 - I Interruptor de alimentación encendido
 - O Interruptor de alimentación apagado

Cable de repuesto

Si es necesario sustituir el cable de alimentación, se debe utilizar un cable de 1mm² de código armonizado H05VV, conectado a un enchufe IEC320. **EN CASO DE DUDA, PÓNGASE EN CONTACTO CON UN ELECTRICISTA.**

CONDICIONES AMBIENTALES

El HB-1D está diseñado para utilizarse en las condiciones siguientes:

- Uso en interior
- Intervalo de temperatura ambiente +5°C a +40°C
- Altitud: hasta 2000 m
- Humedad relativa no superior al 80%
- Fluctuaciones del suministro eléctrico no superiores al 10%
- Categoría de sobrevoltaje II IEC 60364-4-443
- Nivel de contaminación 2
- Separado de paredes u otros objetos a una distancia mínima de 200mm

Nota: Las especificaciones de control corresponden a una temperatura ambiental de 20°C. Las especificaciones pueden empeorar si se utiliza el instrumento fuera del intervalo de temperatura comprendido entre 18°C y 30°C.

Se han realizado pruebas para comprobar la interferencia de radiofrecuencia del instrumento, el cual cumple la normativa EN61326.

GARANTÍA

El instrumento está garantizado contra cualquier defecto en el material o la fabricación durante el período especificado en la tarjeta de garantía que se adjunta. Este período entra en vigor a partir de la fecha de compra. Durante este período, se reemplazarán sin cargo alguno todas las piezas defectuosas, a condición que el defecto sea resultado de un accidente, uso incorrecto o negligencia. El distribuidor del instrumento proporcionará información sobre las reparaciones realizadas bajo esta garantía.

Este manual se ha preparado con una finalidad informativa para los clientes de Techne y ninguna parte del manual se deberá considerar como una garantía, condición o reflejo con respecto a la descripción, comerciabilidad, idoneidad para un fin determinado o de otro tipo de la unidad o sus componentes.

Con independencia de la descripción y las especificaciones del instrumento que se indican en el manual del operario, Techne se reserva el derecho de realizar cambios en el instrumento o en cualquiera de sus componentes cuando lo estime oportuno.

CONTACT INFORMATION

For technical, sales or servicing information, contact your local Techne dealer or:

UK

Bibby Scientific Ltd.
Beacon Road
Stone
Staffordshire
ST15 0SA
UK
Tel: +44 (0)1785 812121
Fax: +44 (0)1785 810405
E-mail: sales@bibby-scientific.com
www.techne.com

France

Bibby Scientific Limited
Bâtiment Le Deltaparc Parc Silic PN2
7 rue du Canal
BP 55437 VILLEPINTE
95944 ROISSY Charles de Gaulle
France
Tel: +33(0)148 63 78 03
Fax: +33(0)148 63 78 01
E-mail: ventes@bibby-scientific.com
www.bibby-scientific.com

Middle East

Bibby Scientific Middle East Ltd.
PO Box 27887, Engomi 2433
Nicosia
Cyprus
Tel: +357 22 660 423
Fax: +357 22 660 424
e-mail: sales@bibby-scientificme.com

North and South America

Bibby Scientific US Inc. t/a Techne Inc.
3 Terri Lane, Suite 10
Burlington, N.J. 08016
USA
Toll Free (in NA): 800-225-9243
Tel: +1 609 589 2560
Fax: +1 609 589 2571
E-mail: labproducts@techneusa.com
www.techneusa.com

Asia

Bibby Scientific - Singapore
Prudential Tower, Level 26
30 Cecil Street
Singapore 049712
Tel: +65 6631 2976
Fax: +44 (0) 1785 810405
e-mail: info@bibby-scientific.com
www.bibby-scientific.com

SPECIFICATIONS

Tube capacity	6 (large and small in any combination) 24 mini tubes (when using the FHB61 mini tube holder) 96 x 15ml tubes (in holder) 48 x 50ml tubes (in holder)
Maximum temperature*	100°C
Minimum temperature	10°C above ambient
Temperature selection	Digital
Adjustable rotation speed	0; 5 to 20 rpm
Adjustable rocking platform (optional)	30 opm recommended
Temperature display	LED
Temperature set point resolution	0.1 °C
Temperature sensor	PRT
Temperature stability in the chamber	≤1.0°C
Temperature stability in the tubes	±0.1 °C
Temperature uniformity in the chamber#	±1.5°C
Temperature uniformity in the tubes#	±1.0°C
Temperature accuracy	±0.3°C
External dimensions (W x D x H)	385 x 285 x 555mm
Internal dimensions (W x D x H)	260 x 210 x 330mm
Electrical supply	230V, 50/60Hz 120V, 50/60Hz
Power	750W
Net weight	20kg
Shipping weight	24kg

Note: The HB-1D includes a pre-set, re-settable over-temperature cut-out.

#Temperature measured in the centre of each tube.

*Large tubes are fitted with seals suitable for use up to 70°C. For higher temperatures, seals part number 6101488 are required.

For the hybridisation tubes see the list under Spares and Accessories

INSTALLATION

See also the sections on Safety and Installation.

1. Place the unit on a suitable flat bench or in a fume cupboard if required, ensuring that the air inlet and outlet vents are free from obstruction.
2. Place some water in a hybridisation tube and fit the tube in the HB-1D. Adjust the feet on the base of the unit by unscrewing them anticlockwise slightly until the unit is level. Check the level by placing the tube in different positions in the oven.
3. Plug the mains cable into the power socket on the rear of the unit.

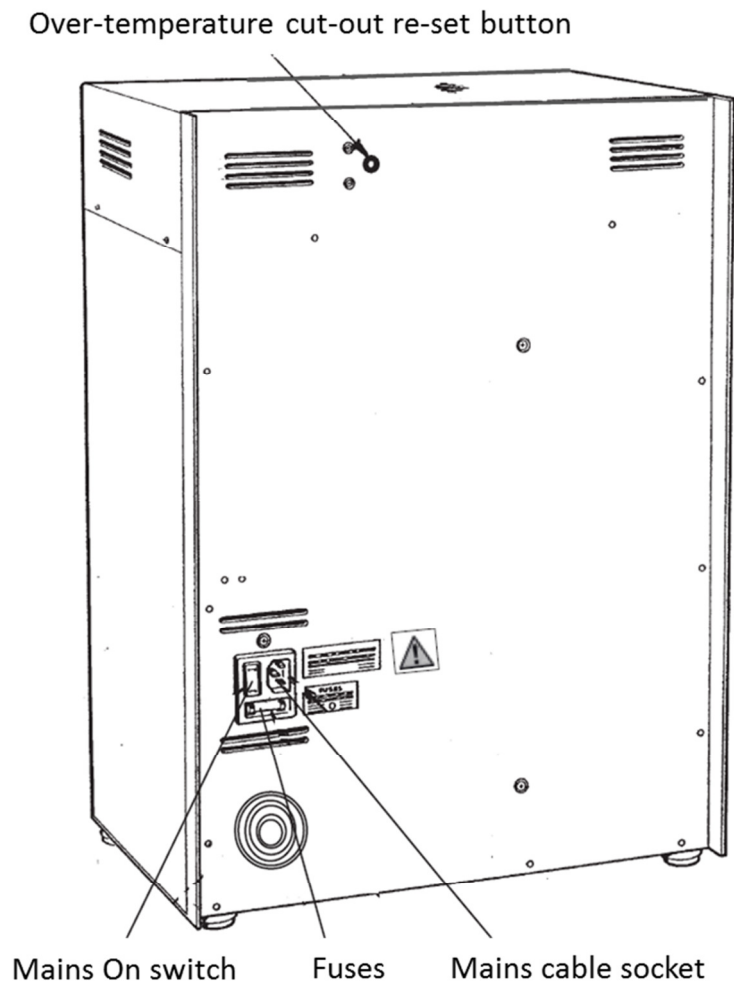

Rear view of the HB-1D

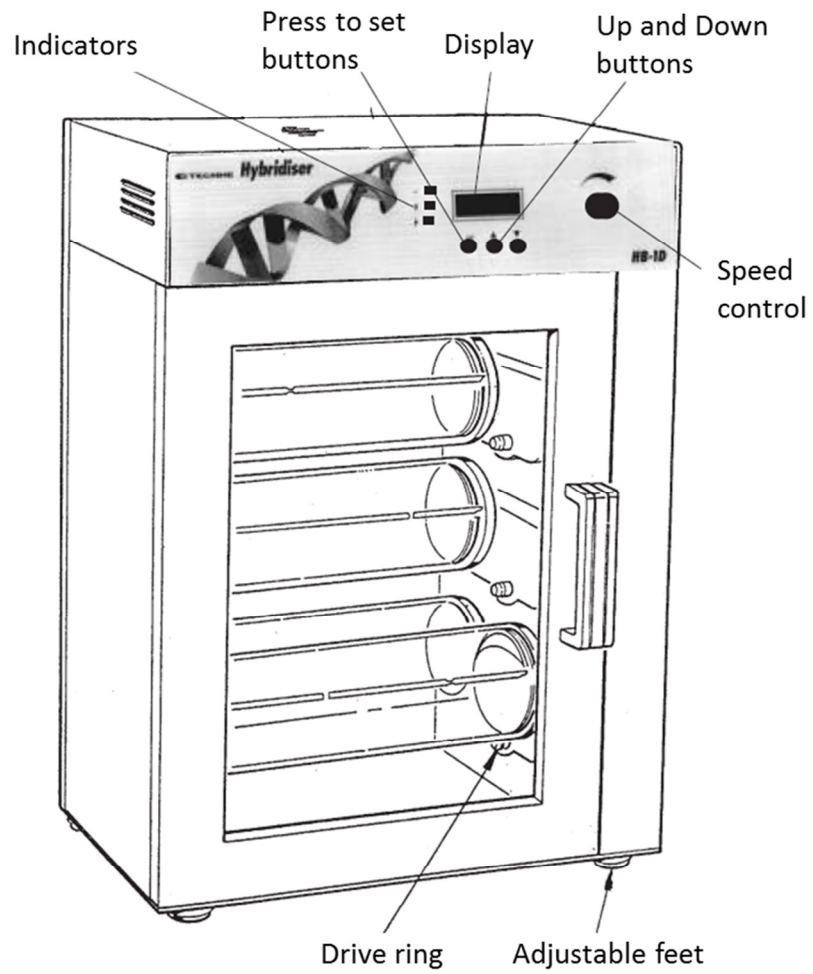

Front view of the HB-1D

OPERATION

SWITCHING ON

Once your HB-1D is connected to a power supply, switch it on using the power switch next to the power inlet socket on the rear panel.

THE FRONT PANEL CONTROLS

The front panel controls consist of a four digit LED temperature display, three buttons for controlling the display, three indicators and a speed control knob for adjusting the tube rotation speed.

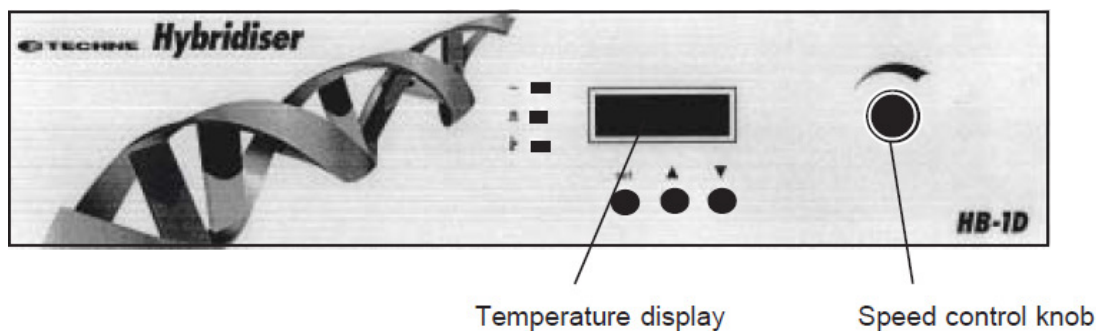

The front panel controls

When you first switch on, the display will show the edition of the software installed on the unit. This will be displayed for 1 second then the actual temperature of the incubator will be indicated.

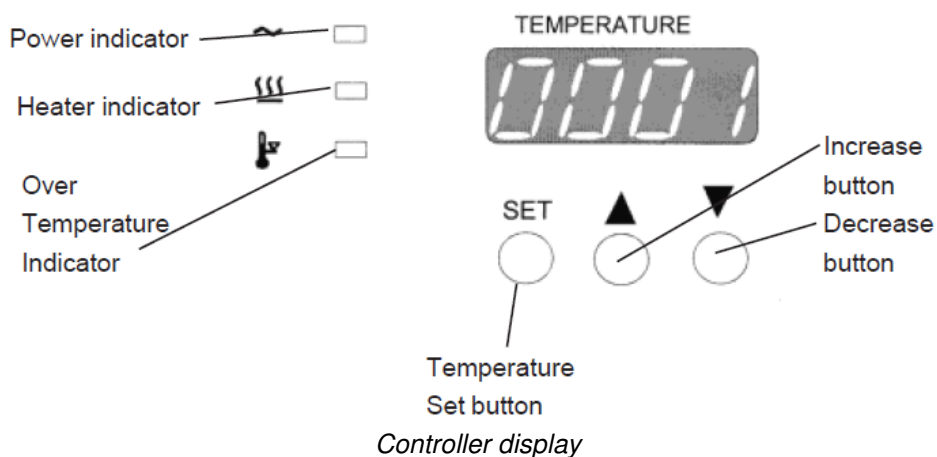

SETTING THE SPEED



Speed control knob

1. When turned fully anticlockwise, the speed control knob switches the rotation of the tubes off.
2. To increase the rotation speed, turn the knob clockwise until you reach the required speed.
3. Operation of the speed control knob increases the speed clockwise and decreases the speed anticlockwise in steps of approximately 4 rpm.

SETTING THE TEMPERATURE

1. To display the set temperature, press the **SET** temperature button:

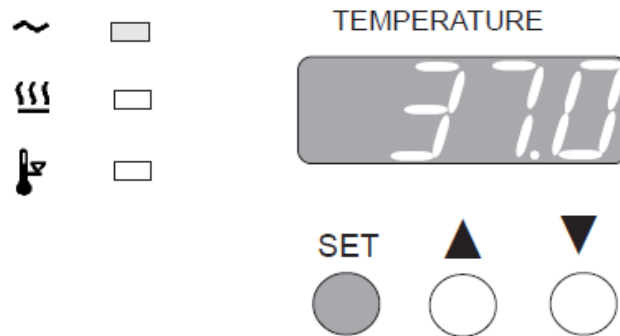

2. To increase the set temperature, hold down the **SET** temperature button and press the **Increase** button.

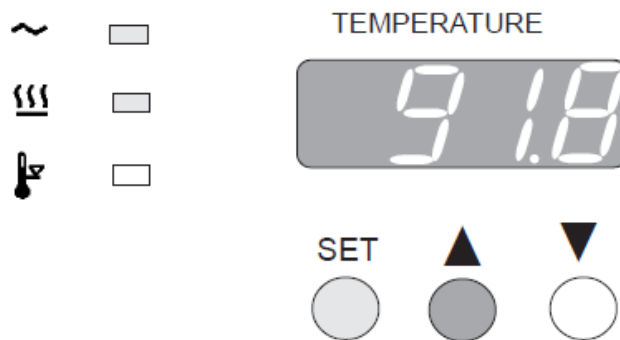

3. To decrease the set temperature, hold down the **SET** temperature button and press the **Decrease** button.

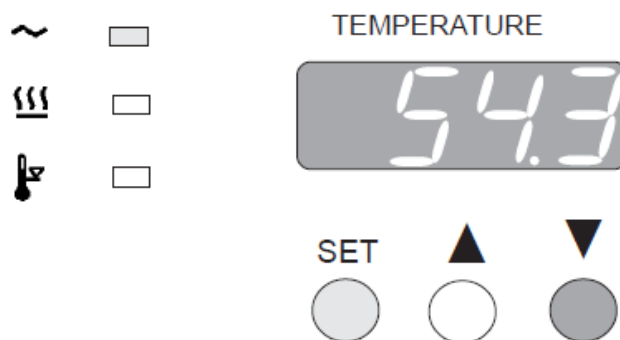

Each press of the **Increase** or **Decrease** buttons will increase or decrease the set temperature by 0.1 °C. If the buttons are held down the temperature change will accelerate to 5°C per second.

Note: It takes approximately 50 minutes for the interior of the hybridisation tubes to reach the displayed temperature depending upon the number of filters and amount of hybridisation fluid used.

INDICATORS

1. Power indicator. When lit, this shows that there is power to the unit.

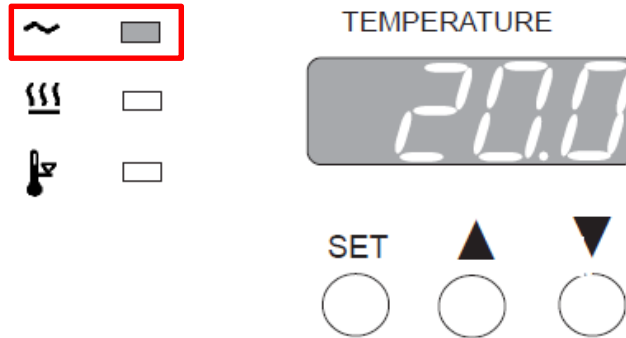

2. Heater indicator. When this is lit or flashing, it indicates that the heater is heating the unit or controlling the temperature. If the oven is above the set temperature then the indicator will be off.

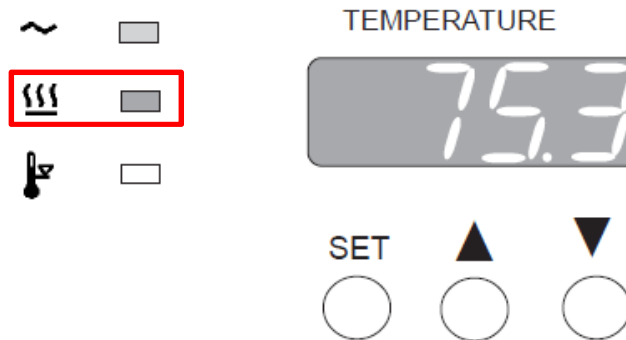

3. Over-temperature indicator. If this is lit, it indicates that the unit has developed a fault and the over-temperature cut-out has been triggered. This will cause the heater to be switched off and the unit will begin to cool even if the heater light is on.

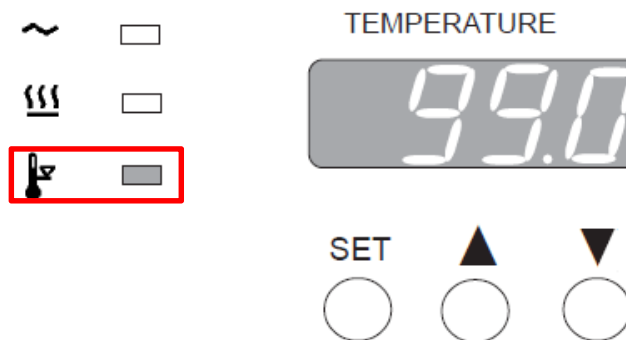

HYBRIDISATION TUBES

The hybridisation tubes are manufactured from durable thick borosilicate glass with a non-drip design. The tubes must be checked regularly and replaced if any damage occurs. Any damage to the ends of the tubes can cause them to break or leak when the end caps are inserted.

Large (80mm diameter) tube assembly (FHB12)

Remove the tube end cap which has the two holes in it. Place the filters in the tube and replace the end cap. A small quantity of Techne O-ring grease (part code 6101351, supplied with the HB-1D) **must** be smeared on the seal to facilitate the insertion of the end caps. Remove the spindle cap and add the fluids appropriate to the protocol through the hole in the spindle using a syringe. Replace the spindle cap and press it onto the spindle so that it clicks into place. Note: the tube will not rotate properly if the cap is not fitted securely.

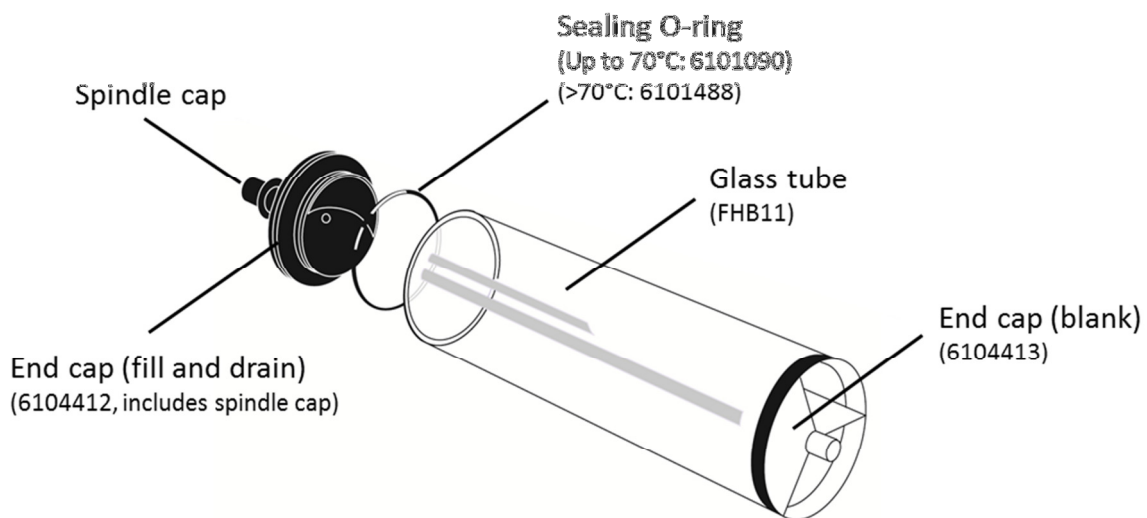

FHB12 assembly

Small (44mm diameter) tube assembly (FHB32)

Unscrew the tube end cap. Place the filters in the tube and replace the end cap. Remove the spindle cap and add the fluids appropriate to the protocol through the hole in the spindle using a syringe. Replace the spindle cap and press it onto the spindle so that it clicks into place.

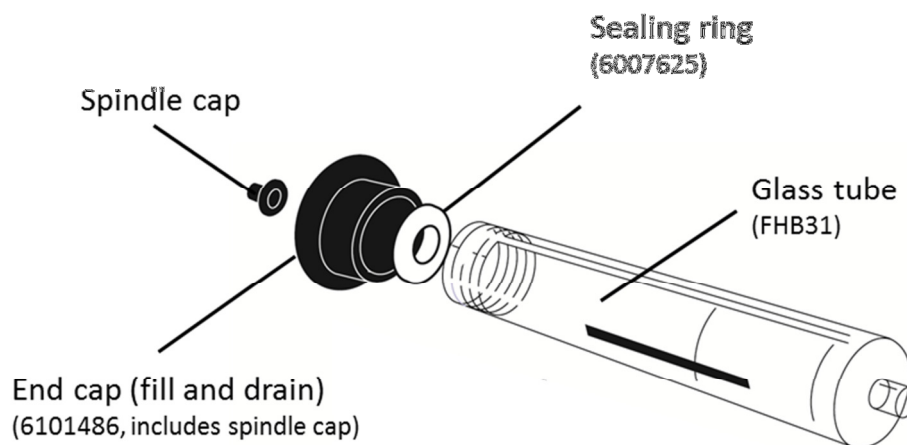

FHB32 assembly

Mini (4 x 32mm) tube assembly (FHB41 and FHB43)

The mini tubes must be used in the FHB43 multi-tube holder. Unscrew the end cap of the tube. Place the filters and the liquids appropriate to the protocol in the tube and replace the end cap. Fix the tube into a multi-tube holder, using the springs, and ensure that there are four tubes in the holder. The end caps must be as shown, on alternate ends. The multi-tube holder will not rotate properly if there are not four mini tubes in it.

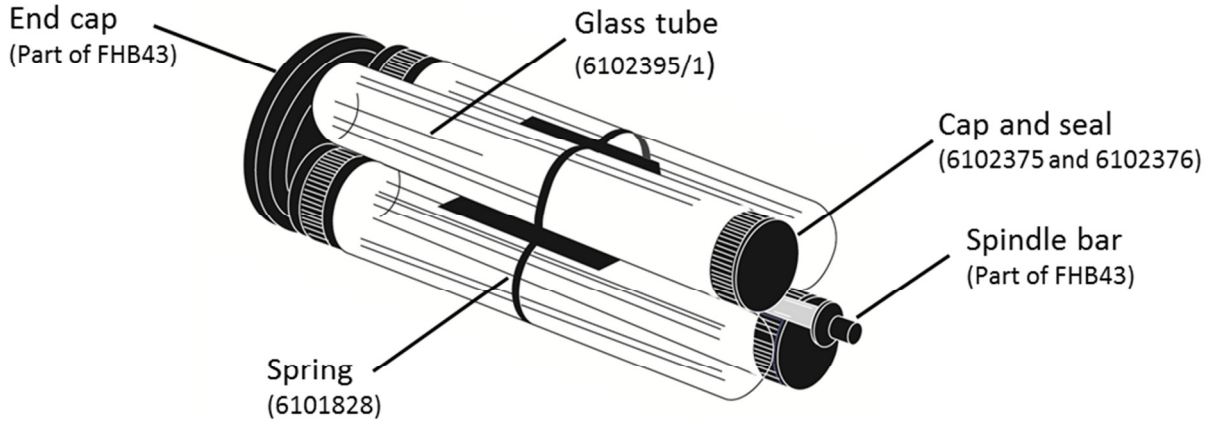

4 x FHB41 and FHB43 assembly

16 x 15ml tube assembly (F15ML1TH) and 8 x 50ml tube assembly (F50ML1TH)

These tube holders are designed to hold 15ml and 50ml Falcon-type tubes. Unscrew the end cap from the tube. Place the filters and the liquids appropriate to the protocol in the tube and replace the end cap. Assemble the tubes into the multi-tube holder using the spring clips to hold them in place. The multi-tube holder will not rotate properly if it is not balanced properly. The multi-tube holder should be filled completely or at least balanced even if all the tubes are not being used.

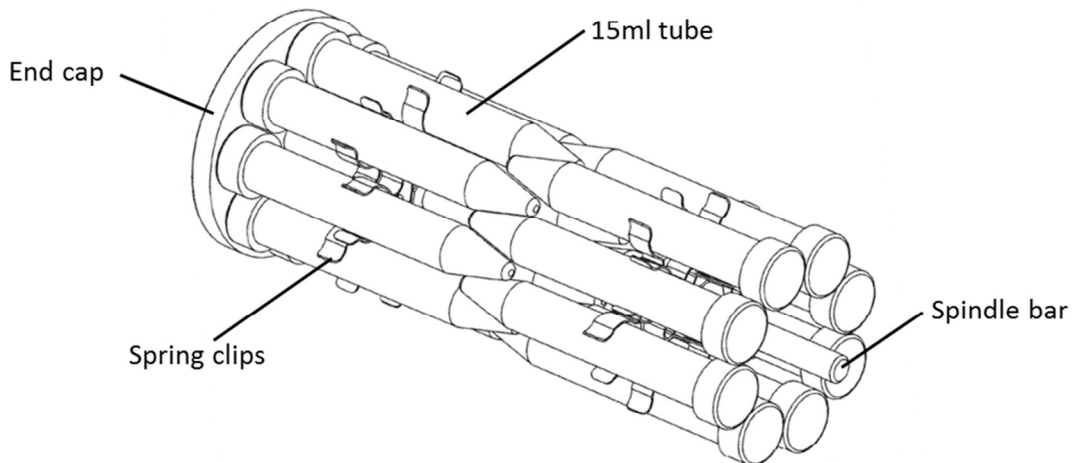

F15ML1TH assembly

INSTALLING THE HYBRIDISATION TUBES

1. Pre-heat the oven to the required temperature.
2. Insert the tubes or tube holder into the HB-1D ensuring that they rotate freely and the end caps engage on the drive rollers on the right hand side of the chamber.
3. Close the door.
4. Turn the speed control knob until you reach the required speed.

BASIC PROTOCOL FOR SOUTHERN HYBRIDISATIONS

Insertion of filters

Place a wet or moist filter, DNA side facing inwards, into a hybridisation tube and roll the tube, allowing the filter to adhere to the glass. Large trapped air bubbles should be smoothed out with a glass pipette; smaller air bubbles are acceptable and do not interfere with hybridisation so long as the surface of the filter is covered with hybridisation fluid.

Several filters may be placed in one tube; there is a slight loss of signal, but no increase in background in the lower filters. To improve the signal we recommend the use of separation membranes between filters, part number FMEM2020.

Pre-hybridisation

Add 5 or 10ml of hybridisation fluid, according to the number of filters and the size of tube, so that the filters are covered. Allow to pre-hybridise for the required period.

Hybridisation

Drain off the pre-hybridisation fluid by removing the spindle cap from the fill and drain hole in the blue end cap and inverting the tube. Add the hybridisation liquid together with the radioactive probe using a syringe and needle through the fill and drain hole and replace the spindle cap. The minimum volume for a single filter is 5ml (when using large tubes). Allow to hybridise for the required period.

Washes

Drain off the hybridisation fluid through the fill and drain hole, collecting the probe in a suitable container for re-use or disposal. Washing depends on the stringency required and usually involves a series of washes with SSC buffer and SDS of decreasing concentration until background radiation has been removed.

Notes:

- All radioactive waste can be collected for disposal; none need be disposed of down the sink.
- Radioactive probes can be collected and reused several times.
- As the protocols for this unit usually involve the use of radioactive materials the appropriate manufacturer's safety precautions must be taken into consideration.

WARNING



THE UNIT WORKS UP TO 100°C. This temperature can cause burns. Bibby Scientific Ltd. takes great efforts to protect operators from hazards, but the following points are brought to your attention:

1. Use care and wear protective gloves to remove hybridisation tubes from the cabinet if the unit is at high temperature. If the protocol allows, it is better to switch off the unit and open the door to allow the unit to cool to below 40°C before attempting to remove the tubes.
2. The coloured end cap of the 80mm large tube and the 44mm small tube has two holes. Take care not to spill radioactive probe through these holes. One hole allows the air to expand when the tube is heated. The other is the fill and drain hole which is revealed when the spindle cap is removed.

DO NOT TIP THE TUBE SO THAT THE COLOURED END IS DOWN AS THIS WILL CAUSE A SPILLAGE.

3. The unit has been designed to conform to international safety specifications and is fitted with a re-settable over-temperature cut-out. If, for any reason, the temperature rises above a safe level for the instrument, the over temperature protection cuts out the heater, but the tubes continue to rotate. Check the reason for the cut-out; if there is no obvious cause, reset the cut-out once the unit has cooled. The reset, on the rear of the unit, is operated by pressing the centre of the button indicated on page 19.

USER MAINTENANCE

O ring seals on the FHB16 hybridisation tubes

The O ring seals on the large 80mm diameter hybridisation tubes must be checked regularly and replaced before a leak occurs. Each tube is provided with 6 spare O rings and further O rings can be obtained from Bibby Scientific Ltd. or your Techne dealer.

Hybridisation tubes

The hybridisation tubes must be checked regularly and replaced if any damage occurs. Any damage to the ends of the tubes can cause them to leak or break when the end caps are inserted. Further tubes can be obtained from Bibby Scientific Ltd. or your Techne dealer.

Cleaning your HB-1D

Before cleaning your unit ALWAYS disconnect from the power supply and allow to cool.

You can clean the case of the HB-1D with a cloth dampened in soapy water. No part of the unit should be immersed in solvents. Do not use acetone or abrasive cleaners.

DO NOT USE ETHANOL OR METHYLATED SPIRITS ON THE ACRYLIC DOOR; these may make the acrylic go cloudy.

Before using any cleaning or decontamination method except those recommended in this manual, the responsible body should check with Bibby Scientific Ltd. that the proposed method will not damage the equipment.

If you spill the fluid

Because of the nature of operation of the HB-1D, the complete inside must be cleaned if a spillage does occur. This is to remove any airborne particles which may have been blown around the system and to guarantee full operator safety.

Switch the HB-1D off and disconnect it from the power supply. Follow this sequence of operations when the HB-1D has been allowed to cool below at least 50 °C:

- Remove all glassware from the HB-1D.
- Remove the plastic drip tray.
- Clean all surfaces of the inner chamber using a suitable cleaning and decontaminating solution. Be careful of the drive shafts.

Cleaning and decontamination materials recommended by Bibby Scientific include:

- Lipsol®
- Decon® 90
- Neutracon®
- Other mild detergent

ADDITIONAL INFORMATION

Note that this equipment should only be dismantled by properly trained personnel. Removing the outer cover exposes potentially lethal mains voltages. There are no user serviceable parts within this equipment.

FAULT FINDING

Should you have any problems with your HB-1D which cannot be easily remedied, you should contact your supplier and return the unit if necessary. Contact the Bibby Scientific Ltd. Service Department (details given below) to obtain information on how to return the unit. Fill in the Decontamination Certificate provided with the unit and include the serial number and details of the fault observed. Please remember to return the unit in its original packing. Bibby Scientific Ltd. accepts no responsibility for damage to units which are not properly packed for shipping: if in doubt, contact your supplier, giving the full serial number of the unit.

FUSES

If the controller fails to light when power is supplied to the unit the fuses may have blown. Check that there is no external cause such as a faulty plug; check both fuses and replace any faulty fuse with one of the correct value. Fuse values are given on the label next to the mains input socket.

SAFETY OVER-TEMPERATURE CUT-OUT

The over-temperature cut-out is a sensitive mechanical device and mechanical shock can cause it to trip.

In the event of no heater power, check the mains plug and lead, then reset the cut-out control by depressing the centre of the button.

Repeated operation of the cut-out indicates a serious fault: you may need to return your unit to your supplier for repair.

IF AN INCORRECT MESSAGE IS DISPLAYED

If a message is displayed which shows an unexpected temperature or HELP, this may indicate a fault with the PRT (temperature sensor). This could indicate for example that a wire has broken; a wire or the connector to the PCB has become disconnected; or the PRT has been broken. You should contact the service department at Bibby Scientific Ltd. or your Techne dealer and return the unit if necessary.

INSULATION TESTING

This equipment is fitted with RFI suppression circuitry. Any check of the electrical insulation by means of high voltage dielectric testing (for example as in BS EN 61010-1) must be carried out using only a DC voltage.

This unit contains semiconductor components which may be damaged by electric field effects.

SUPPORT CONTACTS

If you require further technical or application assistance please contact Techne at:

E-mail: technehelp@bibby-scientific.com.

Phone: +44 (0)1785 810433

For servicing information please contact:

Bibby Scientific Ltd.

Service Department

Beacon Road

Stone

Staffordshire

ST15 0SA

E-mail: service@bibby-scientific.com.

Phone: +44 (0)1785 810475

Please note that neither Bibby Scientific Ltd. nor any of their agents can accept the return of ANY GLASSWARE from these units.

If the unit is returned it must be thoroughly decontaminated and a Decontamination Certificate returned with the unit. A copy of the certificate is available from our website, www.techne.com, or can be requested from the Service Department if the unit is being returned.

We are continually striving to improve our products and software. If you have any comments and suggestions on how we can do things better please send them to us at: technehelp@bibby-scientific.com.

SPARES AND ACCESSORIES

The following spares and accessories may be purchased from Bibby Scientific Ltd. or their dealers. All Techne tubes are made from durable Borosilicate glass. Contact Bibby Scientific Ltd. or your Techne dealer for further details.

Part code	Description
FHB12	Large (80mm diameter) hybridisation tube assembly complete with sealing rings and end caps.
FHB11	Large (80mm diameter) glass tube only
6104412	End cap (fill and drain) for large tubes, includes spindle cap (no sealing ring)
6104413	End cap (blank) for large tubes (no sealing ring)
6101387	Spindle cap (for use with 6104412 and 6101486)
6101090	Sealing ring for large tubes (for 70 °C operation)
6101488	Sealing ring for large tubes (for >70 °C operation)
6101351	Techne O-ring grease (100g tube)
FHB32	Small (44mm diameter) hybridization tube assembly complete with sealing ring and end cap.
FHB31	Small (44mm diameter) glass tube only
6101486	End cap (fill and drain) for small tubes, includes spindle cap (no sealing ring)
6007625	Sealing ring for small tubes
FHB41	4 x 32mm diameter mini tubes
6102395/1	Mini tube, glass tube only
6102375	Cap for use with the mini tube
6102376	Seal for use with the mini tube
FHB43	Multi-tube holder for use with FHB41 (holds 4 mini tubes)
F15ML1TH	16 x 15ml tube assembly (holds 15ml Falcon-type disposable tubes)
F50ML1TH	8 x 50ml tube assembly (holds 50ml Falcon-type disposable tubes)
FHB1/PLAT	Rocking platform
FHBSH1	Stainless steel mesh shelf
FHTRACK	Tube rack/holder (holds 3 large and 3 small tubes)
FMEM2020	Membrane separators 20 x 20cm (pack of 5)
6101668	Drip tray
HH179(S)	UK mains lead with plug, 230V
HH180(S)	European mains lead with plug, 230V
FCABLEUS	US mains lead with plug, 120V

DECLARATION OF CONFORMITY

Declaration of Conformity

Techne HB-1D Hybridiser and Hybrigene Hybridisation Oven

These products comply with the requirements of the EU Directives listed below:

2004/108/EC **EMC Directive.**
2006/95/EC **Low voltage Directive (LVD)**

Compliance with the requirements of these Directives is claimed by meeting the following standards:

EN 61326-1:2006 (Electrical Equipment for Measurement, Control and Laboratory use).
EN 61010-1: 2001
(Safety Requirements Electrical Equipment for Measurement, Control and Laboratory use)
EN 61010-2-010: 2003 (Particular Requirements for Laboratory Equipment for Heating of Materials).
EN61010-2-051: 2003 (Particular Requirements for Laboratory Equipment for Mixing and Stirring)

Compliance Certificates and Equipment Specification.

The full product specifications, listed in report numbers:

RETS(E)1492/A/1

RETS(L)1492/A/2

The above certificates and reports, from an independent test house, are available upon request.

The above certificates and reports, from an independent test house, are available upon request.

CE mark affixed '96.

Signed:  (Mr C. Warren)

Date: 027 09

Authority: Technical Manager
Bibby Scientific Ltd



Bibby Scientific Ltd - Stone - Staffs - ST15 0SA - UK
Tel: +44 (0) 1785 812121 - Fax +44 (0) 1785 813748
DofC_88_Rev01