



Aeolus V

Green Line

Vertical Laminar Flow Cabinets

High quality

Ergonomic design

Low noise level

Energy saving

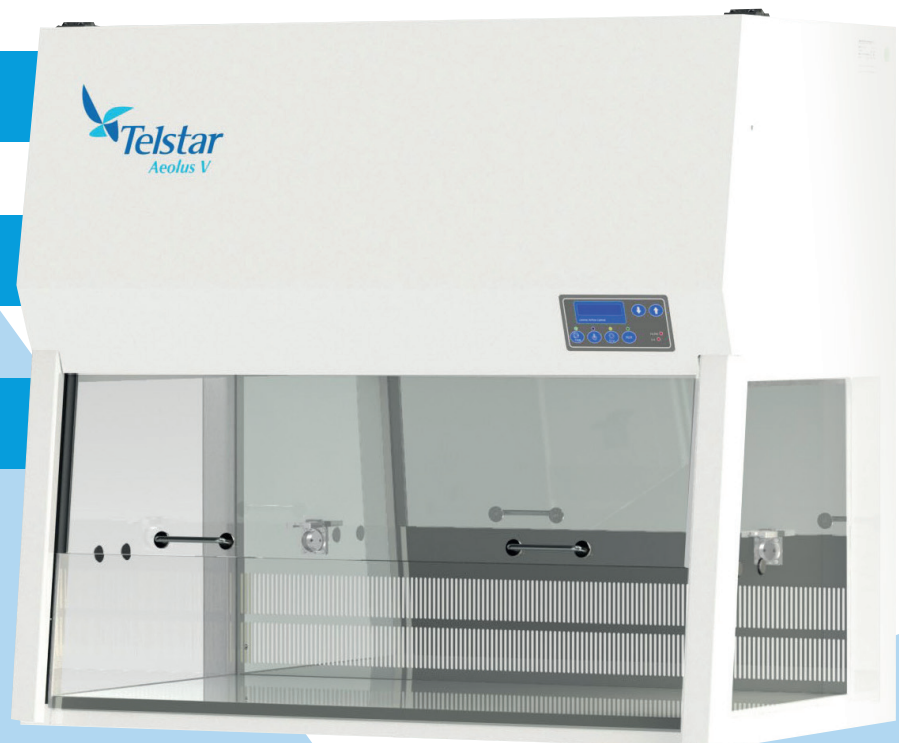

Product protection

Telstar® *Aeolus Series*

Telstar Aeolus V Serie is a high quality vertical laminar flow workbench range for handling non-hazardous materials that require a particle free environment. These cabinets offer the highest product protection.

- Ergonomic design
- High quality
- Low noise level
- Energy saving

International safety standards

The AEOLUS serie is designed and manufactured in order to achieve a working area that meets the ISO 14644-1 (Class 5), GMP Annex 1 (Grade A)*.

Applications

- AEOLUS V Vertical Laminar Flow Benches, have been specially designed to work in Hospitals, Pharmacies, IVF Centers, Food Control, Horticulture in vitro Cultures and also in Electronics, Optics, Micromechanics, Plastic Industries, etc
- Vertical Laminar Flow systems allow operation in sterile and particle free conditions thanks to the continuous flushing of the working area by means of a unidirectional vertical ultrafiltered air flow. The positive pressure inside the cabinet prevents inflow of contaminated air from the surrounding environment into the work area.

Available sizes

AEOLUS Series is available in the following standard sizes 90, 120, 150, 180 cm width (3, 4, 5, 6 feet).

Options & Accessories

The available options and accessories make this cabinet adaptable to many applications.

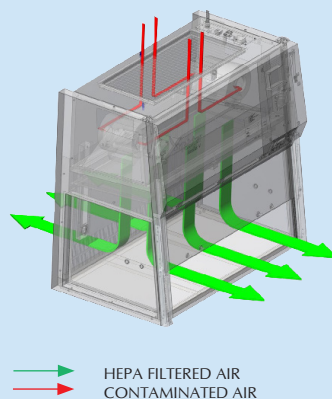
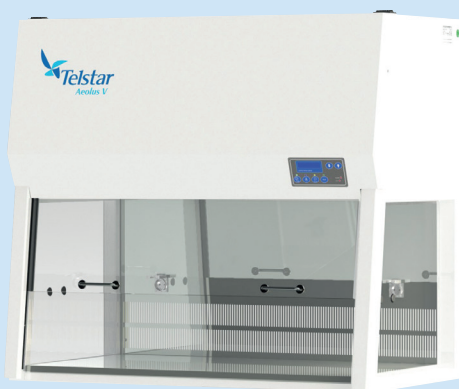

Basic principle

HEPA filtered vertical laminar airflow (downflow) creates an ISO 14644-1 (Class 5) / GMP Annex 1 (Grade A)* work area and prevents ambient air entering the work area, ensuring product protection.

* Former Class 100 according Federal Standard 209E

Features & benefits

General features

High quality components:

- Cabinets made of stove-enamel coated steel
- Polished AISI-304 stainless steel working surface
- HEPA filter protected with laminar screen to provide incomparable uniform flow
- U.V. resistant tempered glass side walls
- Sliding front safety glass window

Ergonomic design:

- Compact external size without parts protruding from the main body; easy to clean
- LED lighting provides uniform illumination and minimises eyestrain
- Low noise level
- User-friendly with intuitive control panel
- Easy installation and service: 800 mm depth allow passage through all doorways. HEPA filter is accessible for replacement from the front of the cabinet. Unit can be fully disassembled in case of complicated installations
- Wide working surface made in Stainless Steel

Green line:

- Very low power consumption is obtained by adopting:
 - EC motors
 - LED lighting
 - Standby flow mode
- All parts are retrofittable, even the metallic ones, so extending total life of the cabinet
- Pre-filter (G3) prevents dust, dirt and particles reaching the HEPA filter, tremendously increasing HEPA filter lifetime

Flexibility:

- Four models with different widths to suit all applications
- Wide range of options and accessories

Control panel with alarms and parameters

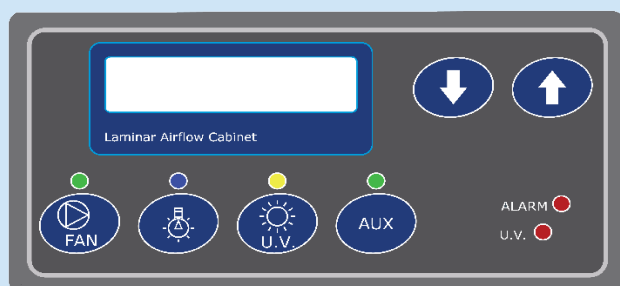

Digital control board with LCD display* including:

- ON/OFF button and light indicator
- Selection of air speed: working or stand-by
- Button for U.V. operation with possibility of exposure time programming
- LEDs on control panel show status of: lighting, U.V., clogging of filter
- Alarm LED
- Display with real-time air speed indication
- Elapsed time counter for the fan and U.V. light

*English, Spanish, French, German, Japanese and Dutch language

Technical Specifications

Features	Unit	Aeolus V 3	Aeolus V 4	Aeolus V 5	Aeolus V6
External dimensions (without support frame)	WxDxH (mm)	1048x798x1220	1353x798x1220	1658x798x1220	1963x798x1220
Internal dimensions	WxDxH (mm)	925x693x615	1230x693x615	1535x693x615	1840x693x615
Weight	Kg	140	160	185	210
Air velocity	m/s	0.36	0.36	0.36	0.36
Consumption	W	112	123	166	188
Lighting	Lux	≥1200	≥1500	≥1500	≥1700
Noise level (according to ISO 11201)	dB (A)	55	55	55	55
Main Filter HEPA H14	Efficiency	Efficiency 99.995%, EN 1822 by MPPS method (99,999% D.O.P. test @ 0.3µm particles)			
Pre-filter Efficiency	EN 779	G3			
Fans		EC High efficiency Centrifugal.			
Coating		Powder coating based on polyester resins			
Working Surface		AISI-304			

Standard Configuration

- Stainless Steel worktop
- 2 Electrical socket(s)
- LED lighting
- EC fans
- Sliding front door, manually operated
- Monitoring of air speed with sensor
- Visual and acoustic alarms

Options & Accessories

- Support stand
- Taps (natural gas, vacuum, O₂, N₂, etc)
- UV light
- Stainless Steel bar with (4 or 6) hooks
- FAT / SAT / IQ / OQ



Distribué par :

Z.A de Gesvrine - 4 rue Képler - B.P.4125
44241 La Chapelle-sur-Erdre Cedex - France
t. : +33 (0)2 40 93 53 53 | f. : +33 (0)2 40 93 41 00
commercial@humeau.com



w w w . h u m e a u . c o m